

# Cut-to-Length Line - Aluminum Service Center

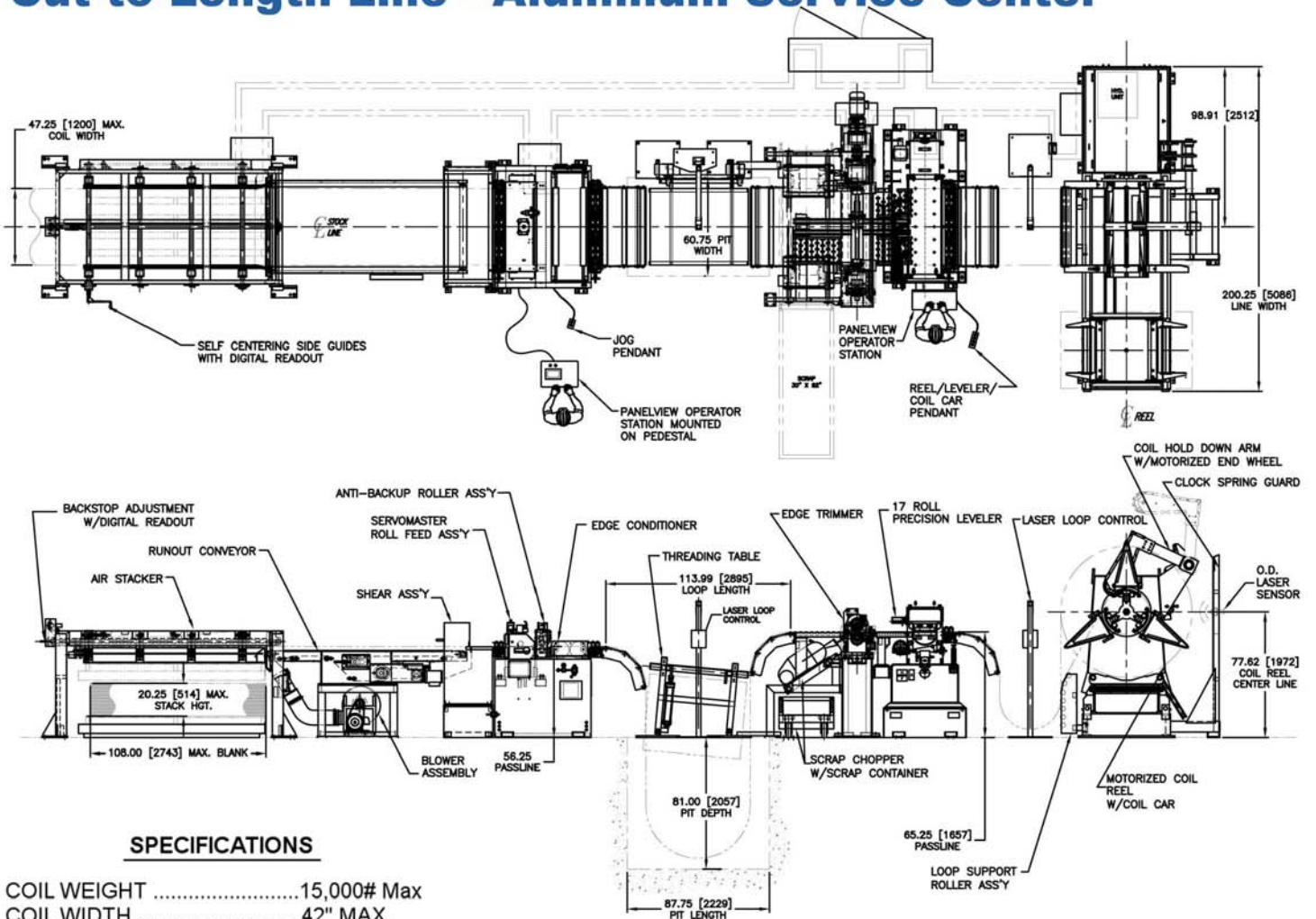

## SPECIFICATIONS

COIL WEIGHT .....	15,000# Max
COIL WIDTH .....	42" MAX.
COIL I.D. ....	19.25" - 24.75"
COIL O.D. ....	72" MAX.
MATERIAL BEING RUN .....	ALUMINUM
MATERIAL THICKNESS .....	.012" - 0.032" @ 42" WIDE
FEED LENGTH ACCURACY...	+/- .003"
LINE SPEED .....	150 FPM
SHEAR SPEED .....	40 SPM MAX.
PASSLINE HEIGHT .....	50" @ FEED
MAX. BLANK SIZE .....	42" X 96"
STACK WEIGHT .....	10,000# MAX.
AIR REQUIREMENTS .....	45 SCFM APPROX.
LINE VOLTAGE .....	480 V., 3PH., 60 Hz, 200A



Aluminum CTL Line with Air Drop Stacker